

## Service Manual

## DVD Player

FILE NO.

**DVD-9201 (SS)**  
**DVD-9501 (SS)**  
**DVD-9501KR (KR)**  
**DVD-9501PR (US)**  
**DVD-9501PR (CA)**

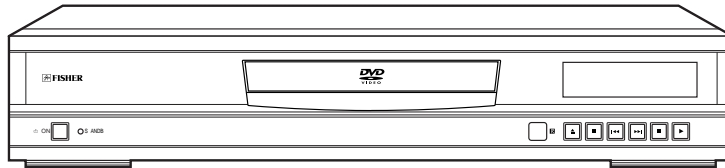

9501PR

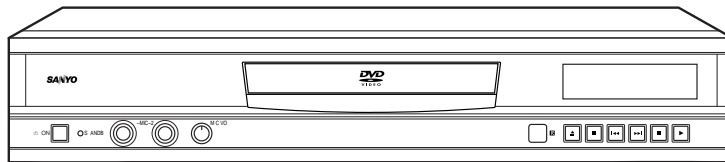
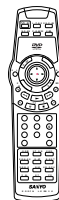

9201,9501,9501KR

### PRODUCT CODE No.

**137 108 04 9201(SS)**  
**137 109 04 9501(SS)**  
**137 109 06 9501KR(KR)**  
**137 108 05 9501PR(US)**  
**137 108 06 9501PR(CA)**

## CONTENTS

Specifications .....	1	Wiring diagram (MPEG A SIDE for 9201) .....	78
Laser beam safety precaution .....	1	Wiring diagram (MPEG B SIDE for 9201) .....	80
DVD Mechanism replacement .....	2	Schematic diagram (DG FRONT for 9201) .....	82
Mechanism replacement .....	3	Schematic diagram (DG FRONT for 9501) .....	84
Mechanism operation .....	4	Schematic diagram (DG FRONT for 9501PR) .....	86
DVD P.W.Board operation .....	5	Schematic diagram (DG FRONT for 9501KR) .....	88
DVD start-up program flow chart .....	28	Wiring diagram (FRONT for 9201, 9501, 9501KR) .....	90
MPEG and FRONT END		Wiring diagram (FRONT for 9501PR) .....	92
P.W.Board operation (block diagram) .....	30	Wiring diagram	
MPEG P.W.Board (schematic diagram for wave check) .	32	(DG,SOCKET for 9501KR and	
AMP P.W.Board (schematic diagram fir wave check) ....	34	POWER SW for 9501KR, 9201 and 9501) .....	94
MPEG and FRONT P.W.Board check waveform .....	36	Wiring diagram	
How to load software for MPEG P.W.Board .....	41	(DG,SOCKET for 9201/SS and	
Trouble shooting .....	42	POWER SW for 9501PR) .....	96
Voltage of IC and Transistor .....	45	Wiring diagram	
Exploded view (cabinet and chassis) .....	49	(DG,SOCKET for 9501/SS and	
Parts list .....	50	MIC for 9501KR, 9201 and 9501) .....	98
Exploded view & Parts list (DVD mechanism) .....	55	Wiring diagram	
IC block diagram and description .....	56	(DG,SOCKET for 9501PR and	
Schematic diagram (MPEG for 9501PR) .....	64	MECHA-M and MECHA-SW) .....	100
Wiring diagram (MPEG A SIDE for 9501PR) .....	66	Schematic diagram (DVD) .....	102
Wiring diagram (MPEG B SIDE for 9501PR) .....	68	Wiring diagram (DVD A SIDE) .....	112
Schematic diagram (MPEG for 9501KR, 9501) .....	70	Wiring diagram (DVD B SIDE) .....	113
Wiring diagram (MPEG A SIDE for 9501KR, 9501) .....	72	Wiring connection .....	114
Wiring diagram (MPEG B SIDE for 9501KR, 9501) .....	74	IC block diagram and description .....	rear
Schematic diagram (MPEG for 9201) .....	76		

## SPECIFICATIONS

Playback system ..... DVD-Video , Video CD , CD  
 Playback standard ..... NTSC or PAL  
 Laser ..... Semiconductor laser,  
 wavelength 650/790nm  
 Laser output  
 (Continuous wave max.) :  
 1 mW(DVD) , 0.5 mW(CD)

Frequency range (digital audio)

..... 4 Hz to 22 kHz

Signal to noise ratio ..... More than 105 dB

Harmonic distortion ..... 0.003 %

Wow and flutter ..... Below measurable level

Output:

DIGITAL OUTPUT :

For optical cable

COMPONENT VIDEO OUT

Y ..... 1.0 Vp-p (75 ohm)

C<sub>B</sub> , C<sub>R</sub> ..... 0.7 Vp-p (75 ohm)

S-VIDEO OUT

Y ..... 1.0 Vp-p (75 ohm)

C ..... 0.286 Vp-p (75 ohm) (NTSC)

0.3 Vp-p (75 ohm) (PAL)

VIDEO OUT ..... 1.0 Vp-p (75 ohm)

AUDIO OUT ..... L, R : 2.0 V rms

5.1CH DISCRETE AUDIO OUT ... FRONT L, R: 2 V rms

(9501/SS, 9501KR/KR) SURROUND L, R: 2 V rms

CENTER: 2 V rms

SUB WOOFER: 2 V rms

Power requirements ..... AC 220 V 60 Hz(KR)

110 - 240 V, 50/60 Hz(SS)

120 V, 60 Hz(US, CA)

Power consumption ..... 14.5 Watts

Dimensions (W x H x D) ..... Approx. 435 x 79 x 281 mm

Weight ..... Approx. 3 Kg

Specifications subject to change without notice.

## LASER BEAM SAFETY PRECAUTION

- Pickup that emits a laser beam is used on this DVD section.

CAUTION :

USE OF CONTROLS OR ADJUSTMENTS OR  
 PERFORMANCE OF PROCEDURES OTHER  
 THAN THOSE SPECIFIED HEREIN MAY RESULT  
 IN HAZARDOUS RADIATION EXPOSURE.

LASER OUTPUT ..... 1/0.5 mW Max. (CW)

WAVE LENGTH ..... 650/790 nm

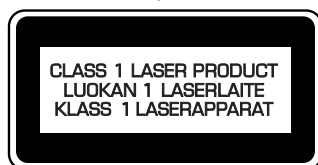
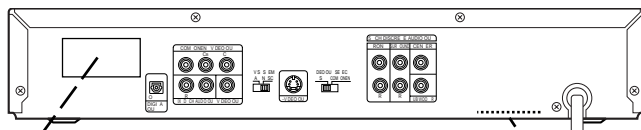

CAUTION – INVISIBLE LASER RADIATION WHEN OPEN AND  
 INTERLOCKS DEFEATED. AVOID EXPOSURE TO BEAM.

ADVARSEL – USYNLIG LASER STRÅLING VED ÅBNING, NÅR  
 SIKKERHEDSAFBRYDERE ER UDE AF FUNKTION, UNDGÅ UDSÆTTELSE  
 FOR STRÅLING.

VARNING – OSYNLIG LASER STRÅLNING NÅR DENNA DEL ÄR ÖPPNAD  
 OCH SPÄRR ÄR URKOPPLAD. STRÅLEN ÄR FARLIG.

VORSICHT – UNSICHTBARE LASERSTRAHLUNG TRITT AUS, WENN  
 DECKEL GEÖFFNET UND WENN SICHERHEITVERRIEGELUNG  
 ÜBERBRÜCKT IST. NICHT, DEM STRAHL AUSSETZEN.

VARO – AVATTAESSA JA SUOJALUKITUS OHITETTAESSA OLET ALTTI NA  
 NÄKYMÄTTÖMÄLLE LASERSÄTE LYLLE. ÄLÄ KATSO SÄTEESEEN.



## DVD MECHANISM REPLACEMENT

---

1. Cautionary instructions in handling the assy  
(Safety instructions)

Optical pickup

The laser beam used in the pickup is classified as "class 2". Exposing your eyes or skin to the beam is harmful. Take care not to do so.

(Caution against static electricity and leakage voltage)

Ground securely the work tables, tools, fixtures, soldering irons (including those made of ceramic) and measuring instruments used in the production lines and inspection departments that handle loaders. The workers shall also be grounded.

(Cautionary instructions in handling)

Do not touch the object lens when handling a loader, or the lens will be stained, resulting in inadequate playability.

There is no power supply protection circuit provided for this product or adjustment/inspection device. Short-circuiting may lead to fire or damage.

Take care so as to protect from exposure to water, the entry of metallic pieces or dew condensation.

In particular, a strong magnet adjacent to the pickup will not only get inoperative but can damage the pickup if a small metallic piece, such as a screw or swarf, enters.

The loader edge can cause injury if inadvertently handled.

Do not touch a rotating disk, or injury may result.

This product is a precision device. Handle carefully.

A shock or dropping will cause misalignment or destruction. If it should occur, refer to clause 2.

This product is so designed as to endure an initial shock equivalent to a drop from a height of approx. 90 cm under the packed condition.

After the initial shock, the resistivity will still remain at a level of 50 to 60 G, but the mechanical robustness will weaken.

Do not place in a dusty location.

The entry and deposition of dirt into or on the pickup lens or moving section will cause malfunction or degradation.

(Connectors)

Do not connect or disconnect while power is on.

Connecting or disconnecting signal wires or the main power cord when the power is on may destruct the unit or fixture.

When connecting, push all the way in securely.

An insufficient insertion may cause a bad contact, leading to an erroneous operation.

Do not connect or disconnect roughly by an excessively strong force, or a broken wire or bad contact may result.

Semiconductors are connected. Do not touch connector terminals directly.

If the worker is grounded, there is nothing to worry about static electricity, but the rust on the connector terminal surface caused by the touch may result in bad contact.

(Power source)

The power source need be good in quality (free from instantaneous interruptions or noises).

A low quality power source may well cause malfunction.

(Storage)

Do not place or store in a dusty place or a place where dew condensation is possible.

The entry and deposition of dirt or dust into or on the pickup lens or moving section will cause malfunction or degradation.

Also, dew condensation causes rust; the rust penetrates into the precision part of a pickup, causing malfunction, or degrading the optical quality of the internal lens and reflector, which also leads to malfunction.

# MECHANISM REPLACEMENT

## 1. TRAY AND BASE MECHANISM PART

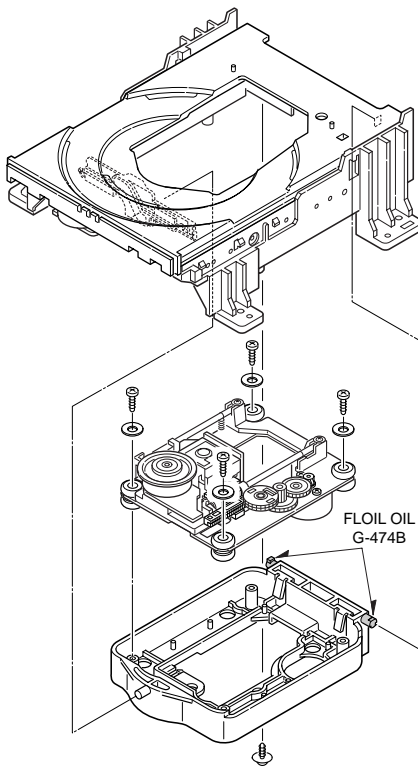

## 2. Base mechanism mounting PART

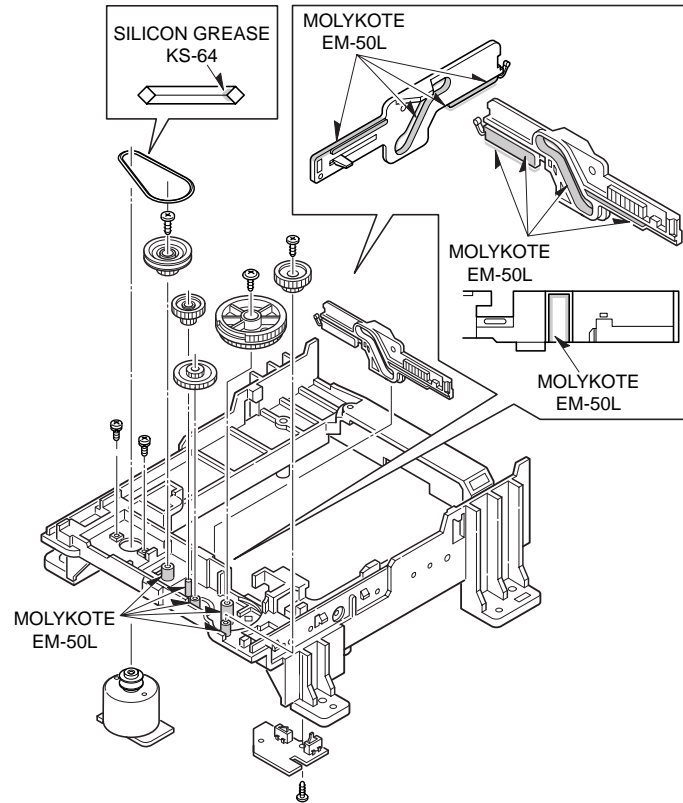

## 3. TRAY PART

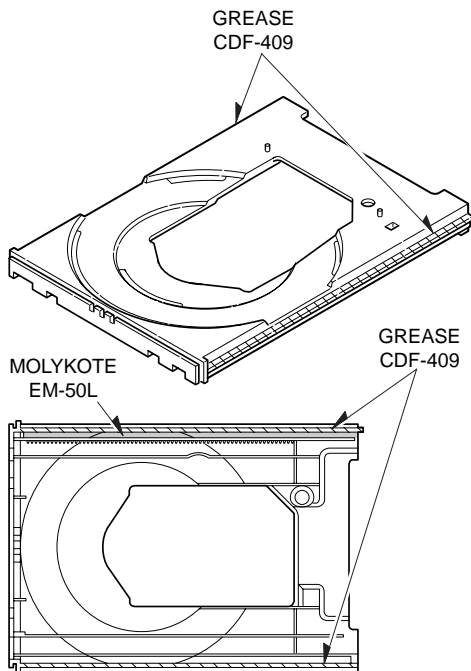

## 4. BASE MECHANISM PART

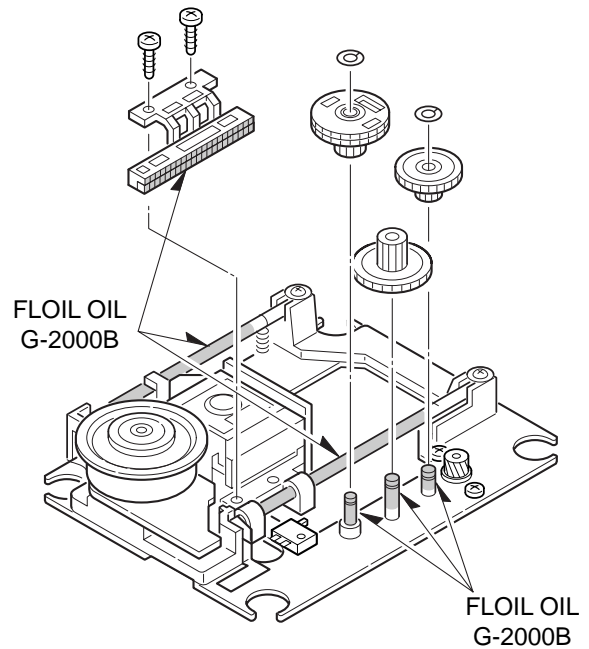

Do not remove the pick-up from base mechanism because of adjustment difficulty.

# MECHANISM OPERATION

## 1. How to setting the tray.

1. Move the SLIDE left side.
2. Match the Hole of GEAR ⑤ and Hole of CHASSIS ④.

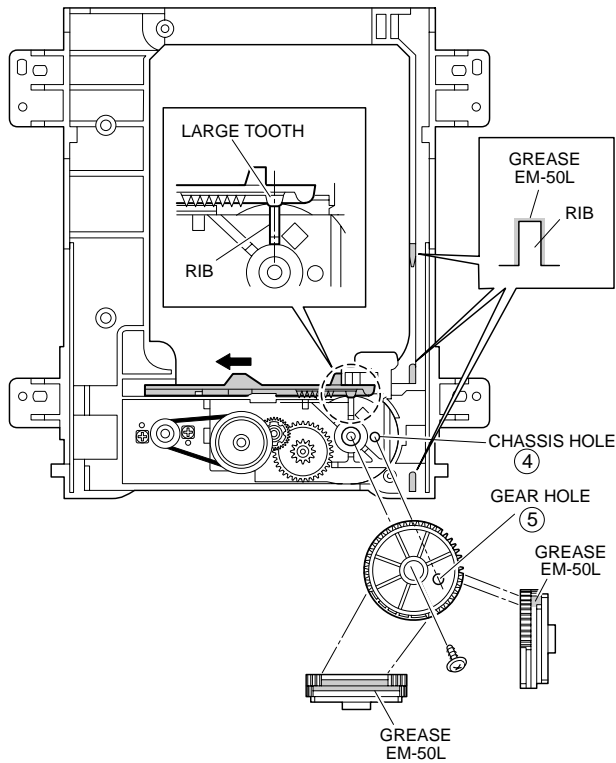

3. Match the mark of GEAR ② and mark of GEAR ③, and then install the BOSS.
4. Turn the GEAR ① counterclockwise, and then SLIDE move right side.
5. The GEAR ① move from side to side.

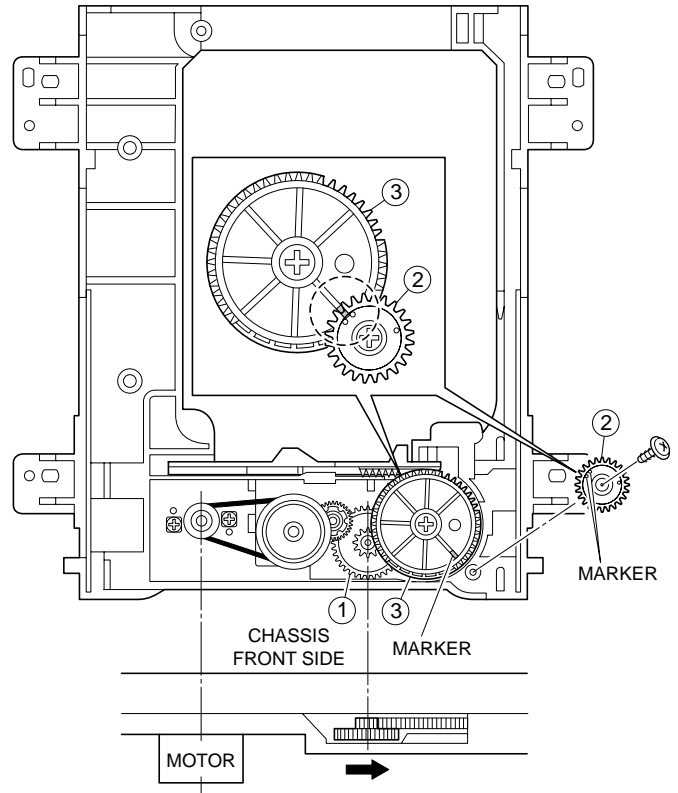

6. Match the hole of GEAR ⑦ and hole of chassis while turning GEAR ⑥.
7. Match the mark of LOADING GEAR ⑧ and gear of TRAY where see horn hole ⑨ of tray.
8. Push a tray with the state that turned the entire surface of a tray into approximately 5 degrees the lower part slowly.

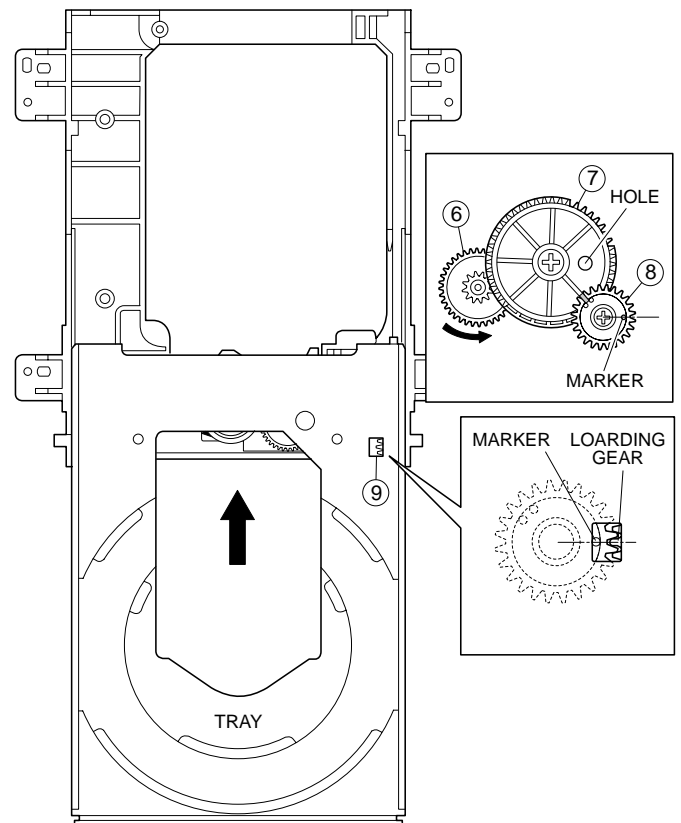

# DVD P.W.BOARD OPERATION

## 1. General operation diagram (This is a basic general operation diagram)

The circuit mounted on the Loader part (Frontend Board) is configured as shown, which is divided into following blocks according to main ICs.

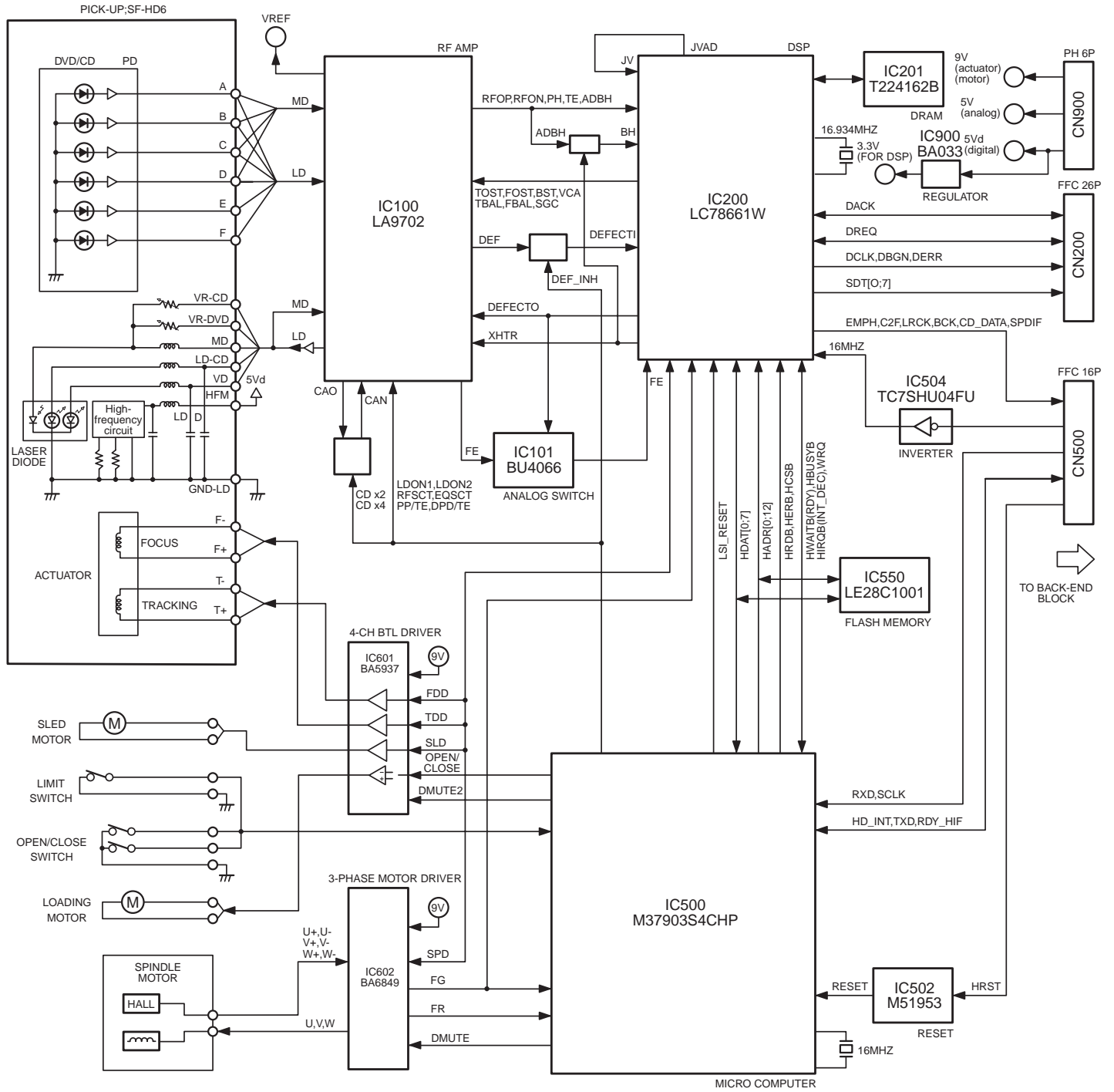

# DVD P.W.BOARD OPERATION

## 2. Circuit configuration inside IC100(LA9702W) and IC200(LC78660W) (This is a basic circuit configuration.)

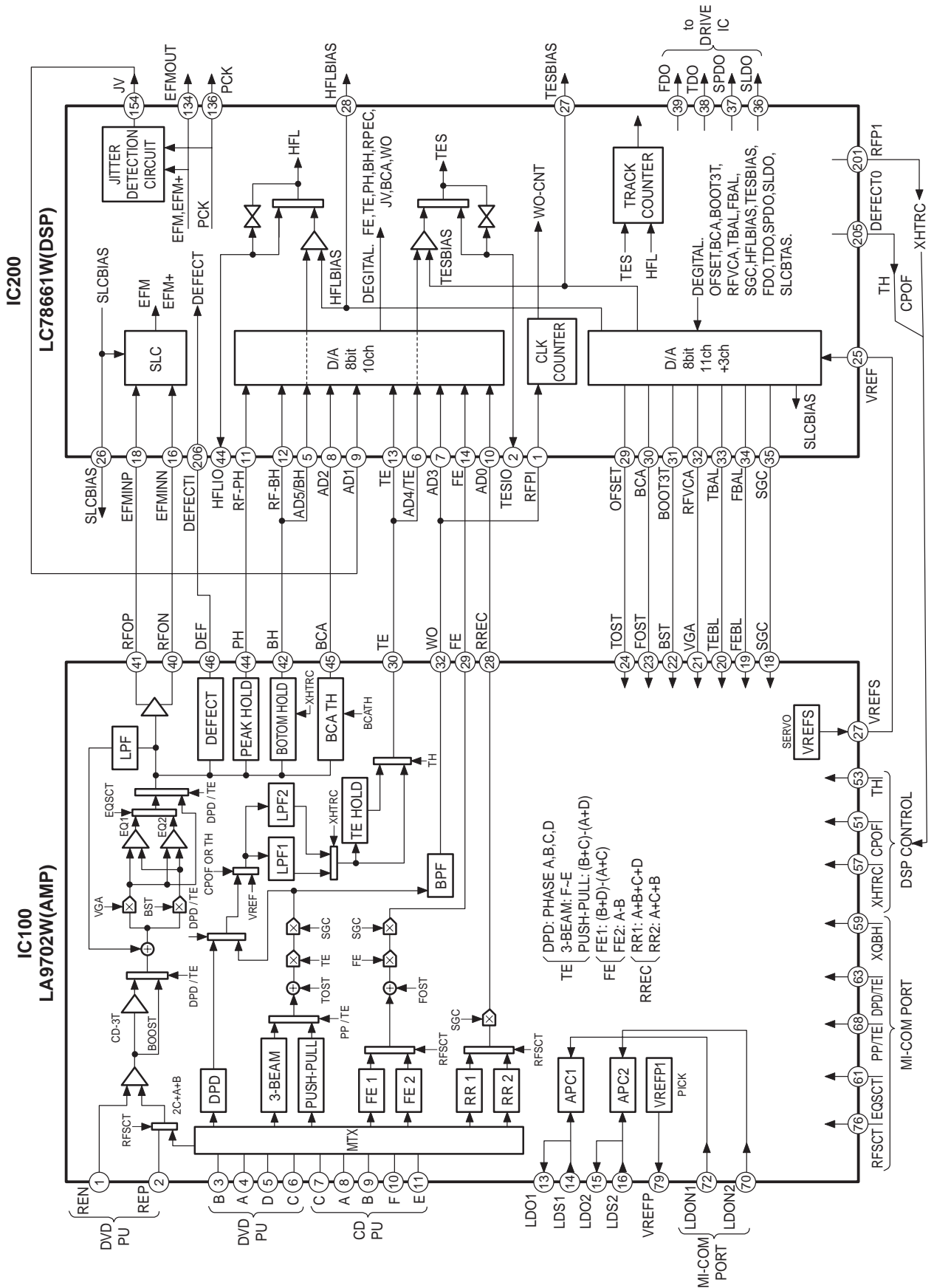

## DVD P.W.BOARD OPERATION

### 3. Table of monitor signals (This is a basic table of monitor signals)

A. Reference table for waveform are listed as below.

Name	TP label	IC, CN Location	Pin no.	Description
FE	TP101	IC100	25	Focus Error Signal(Analog)
TE	TP102	IC100	30	Trk Error Signal(Analog)
RFN	TP104	IC100	40	RF Signal(Analog)
RFP	TP105	IC100	41	RF Signal(Analog)
BH	TP106	IC100	42	Bottom Hold Signal(Analog)
PH	TP107	IC100	44	Peak Hold Signal(Analog)
DEF	TP230	IC100	46	High : When passing defection
LD1	TP122	Q1004	E	DVD Laser Power Supply(Analog)
LD2	TP124	Q1005	E	CD Laser Power Supply(analog)
TESI0	TP201	IC200	2	TES(Track crossing signal)
HFLBIAS	TP204	IC200	28	MIRROR Slice Bias(Analog)
HFLIO	TP206	IC200	44	MIRROR signal
FSEQ	TP211	IC200	84	High : Sync synchronised LO : Async
EFMOUT	TP226	IC200	134	RF Digitized signal
DEFECT0	TP229	IC200	201	High : When passing defection
TOST	TP246	IC200	29	Trk Offset Control(analog)
FOST	TP247	IC200	30	Focus Offset Control(analog)
BOOST3T	TP248	IC200	31	RF EQ Control(analog)
RFVCA	TP249	IC200	32	RF Voltage Control(analog)
TBAL	TP250	IC200	33	Trk Balance Control(analog)
FBAL	TP251	IC200	34	Fcs Balance Control(analog)
SGC	TP252	IC200	35	Signal Gain Control(analog)
HFBUSYB	TP254	IC200	50	Function Busy Low during jump, adjustment so on.
JVAO	TP257	IC200	154	Jitters value(analog)
TD	TP601	IC200	38	Trk Driver out(analog)
FD	TP602	IC200	39	Focus Driver out(analog)
SPD-FG	TP604	IC602	24	Spindle FG signal
W	TP621	-----	-----	Spindle Coil Voltage
V	TP620	-----	-----	
U	TP611	-----	-----	
H+	TP619	-----	-----	Spindle Hall Voltage
U+	TP618	-----	-----	
U-	TP617	-----	-----	
V+	TP616	-----	-----	
V-	TP615	-----	-----	
W+	TP614	-----	-----	
W-	TP513	-----	-----	
H-	TP612	-----	-----	
SLD	TP607	IC200	36	Sled Driver out(analog)
SPD	TP608	IC200	37	Spindle Driver out(analog)
OPEN	-----	IC601	16	TRAY control signal
CLOSE	-----	IC601	15	TRAY control signal
OPEN-SW	TP627	CN600	5	TRAY Limit SW
CLOSE-SW	TP626	CN600	3	TRAY Limit SW
HRST	TP700	CN500	2	RESET from Backend
RESET	-----	IC502	6	RESET to Micom
VREF	-----	IC100	27, 79	Reference Voltage(2.5V)



**DVD P.W.BOARD OPERATION(SCHEMATIC DIAGRAM FOR SIGNAL CHECK)**  
 (This is a basic schematic diagram and signal check.)

Top left zoon , There is the drawing which zoomed to 10,11 page.

Top right zoon , There is the drawing which zoomed to 12,13 page.

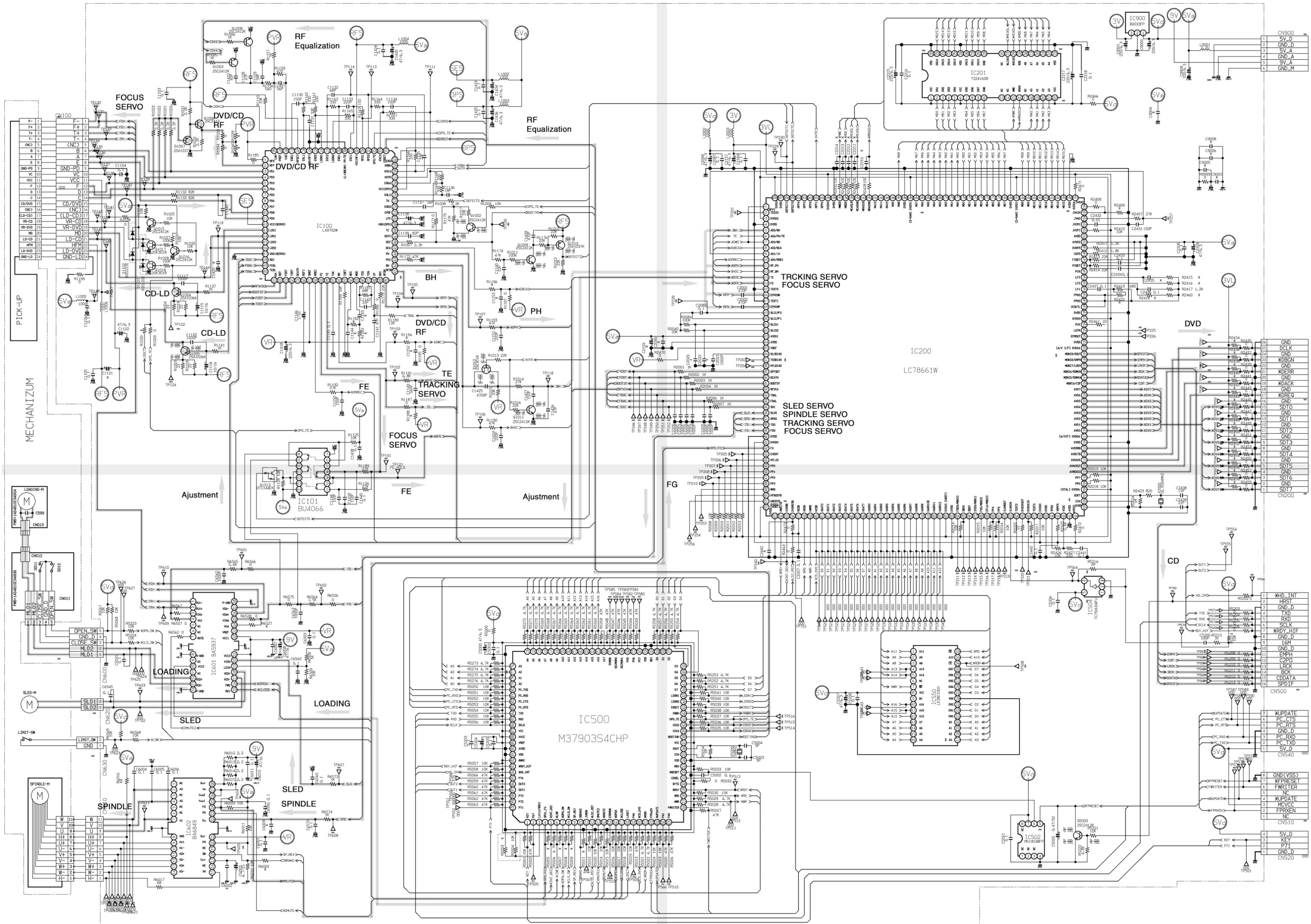

Bottom left zoon , There is the drawing which zoomed to 14,15 page.

Bottom right zoon , There is the drawing which zoomed to 16,17 page.

DVD P.W.BOARD OPERATION(SCHEMATIC DIAGRAM FOR SIGNAL CHECK for top left)  
 (This is a basic schematic diagram and signal check.)

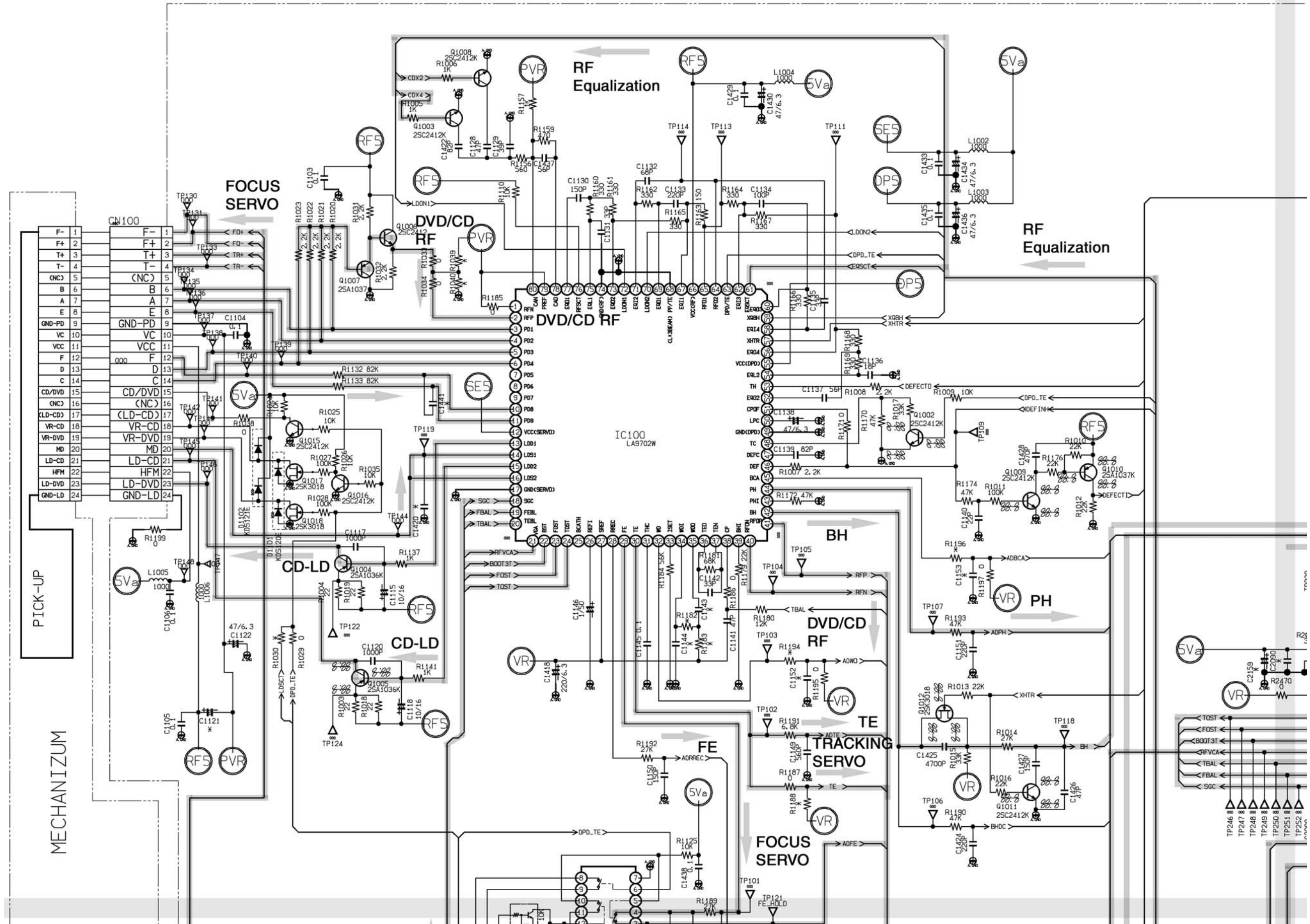

**DVD P.W.BOARD OPERATION(SCHEMATIC DIAGRAM FOR SIGNAL CHECK for top right)**  
 (This is a basic schematic diagram and signal check.)

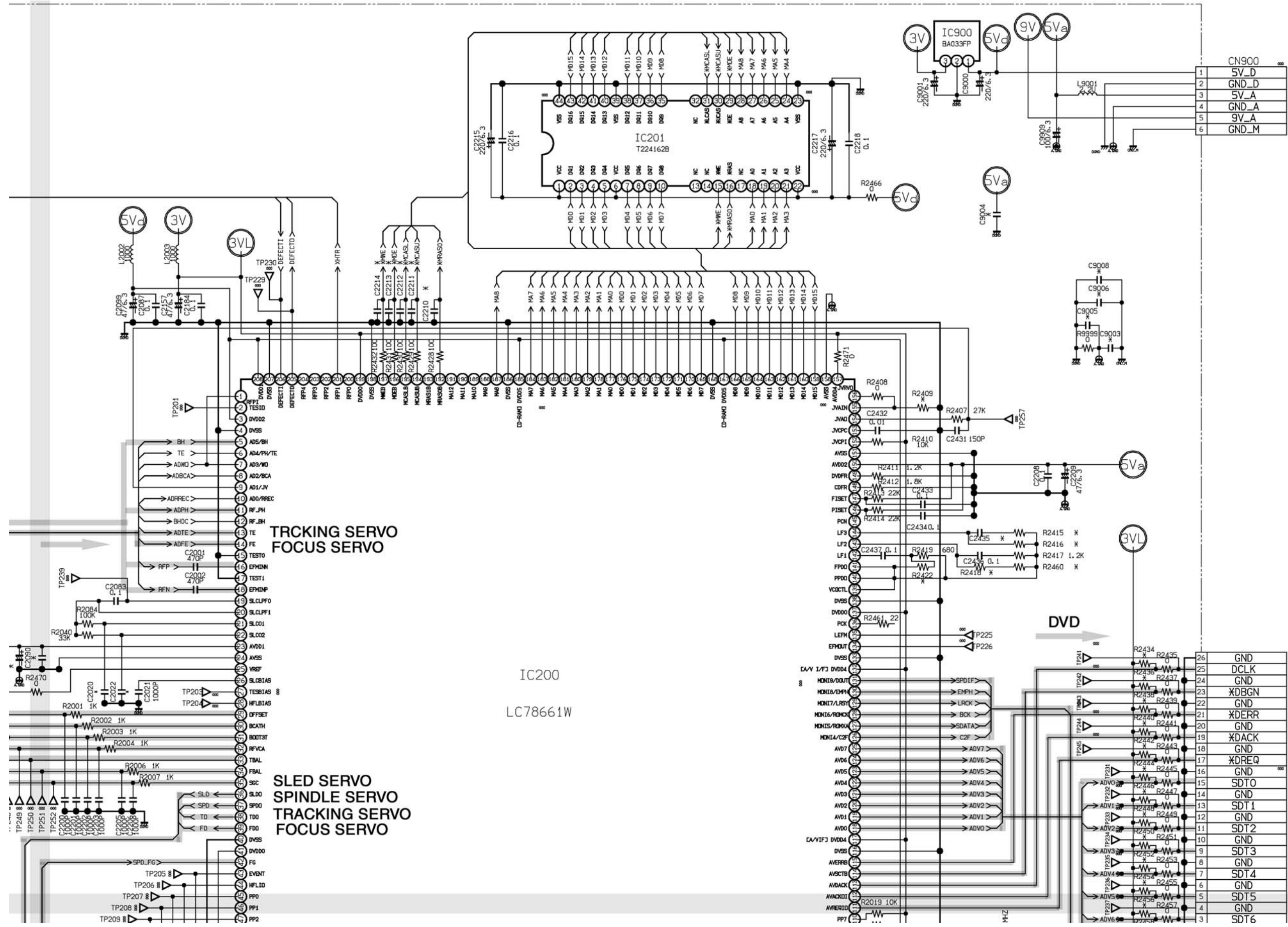





**DVD P.W.BOARD OPERATION(SCHEMATIC DIAGRAM FOR SIGNAL CHECK for bottom right)**  
 (This is a basic schematic diagram and signal check.)

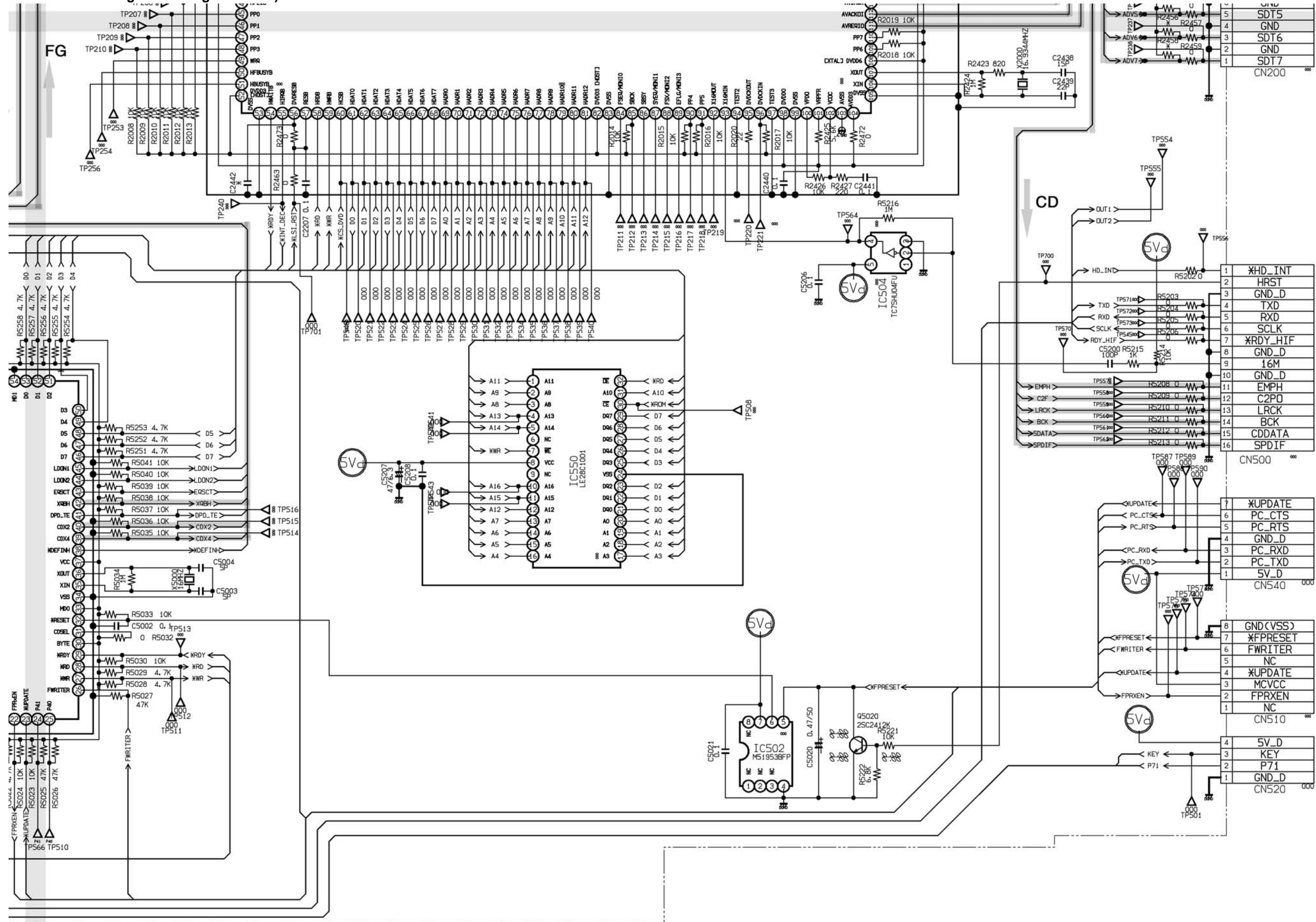

# DVD P.W.BOARD OPERATION(WIRING DIAGRAM FOR SIGNAL CHECK)

A. A side (This is a basic wiring diagram and signal check.)

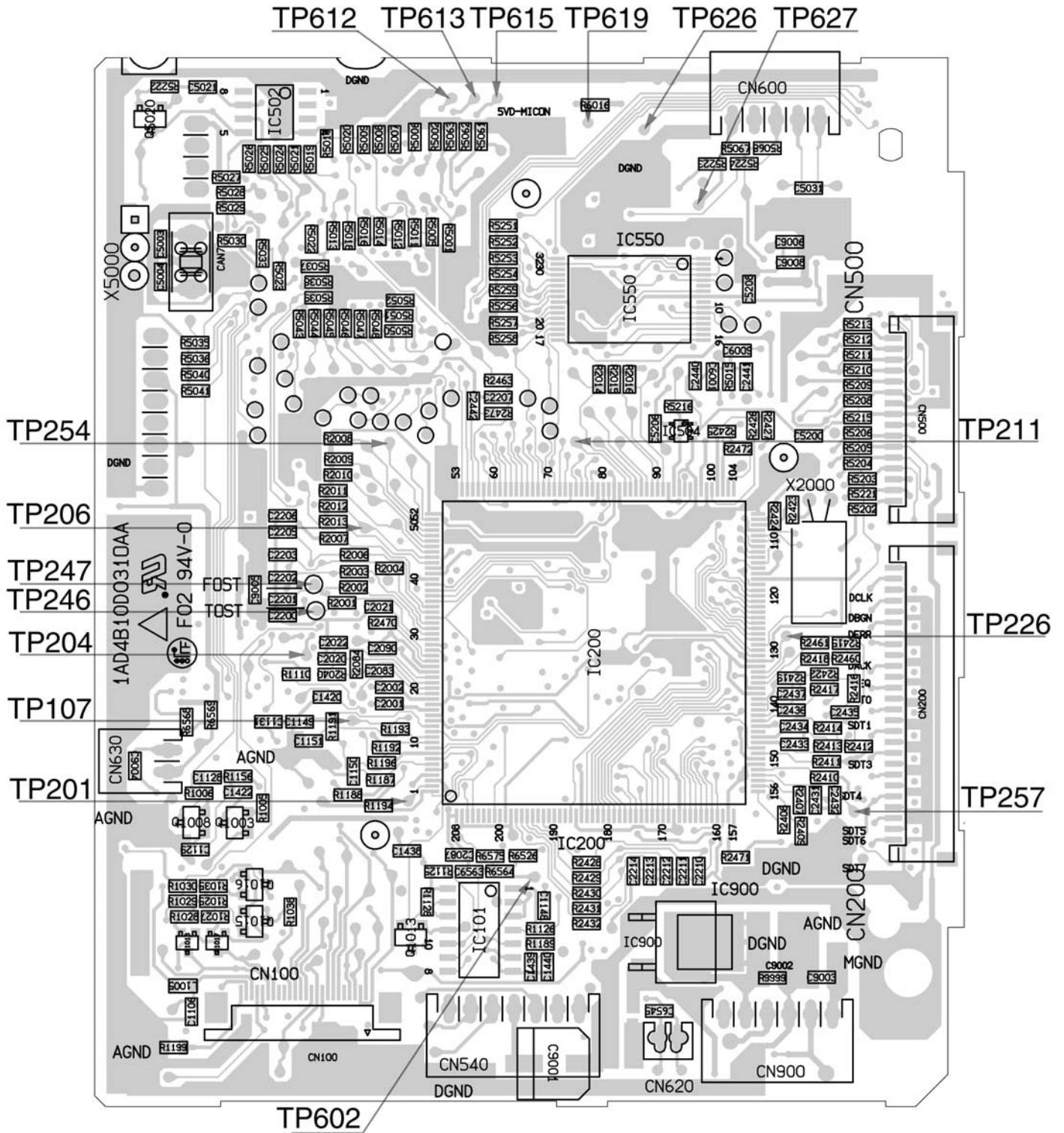

# DVD P.W.BOARD OPERATION(WIRING DIAGRAM FOR SIGNAL CHECK)

B. B side (This is a basic wiring diagram and signal check.)

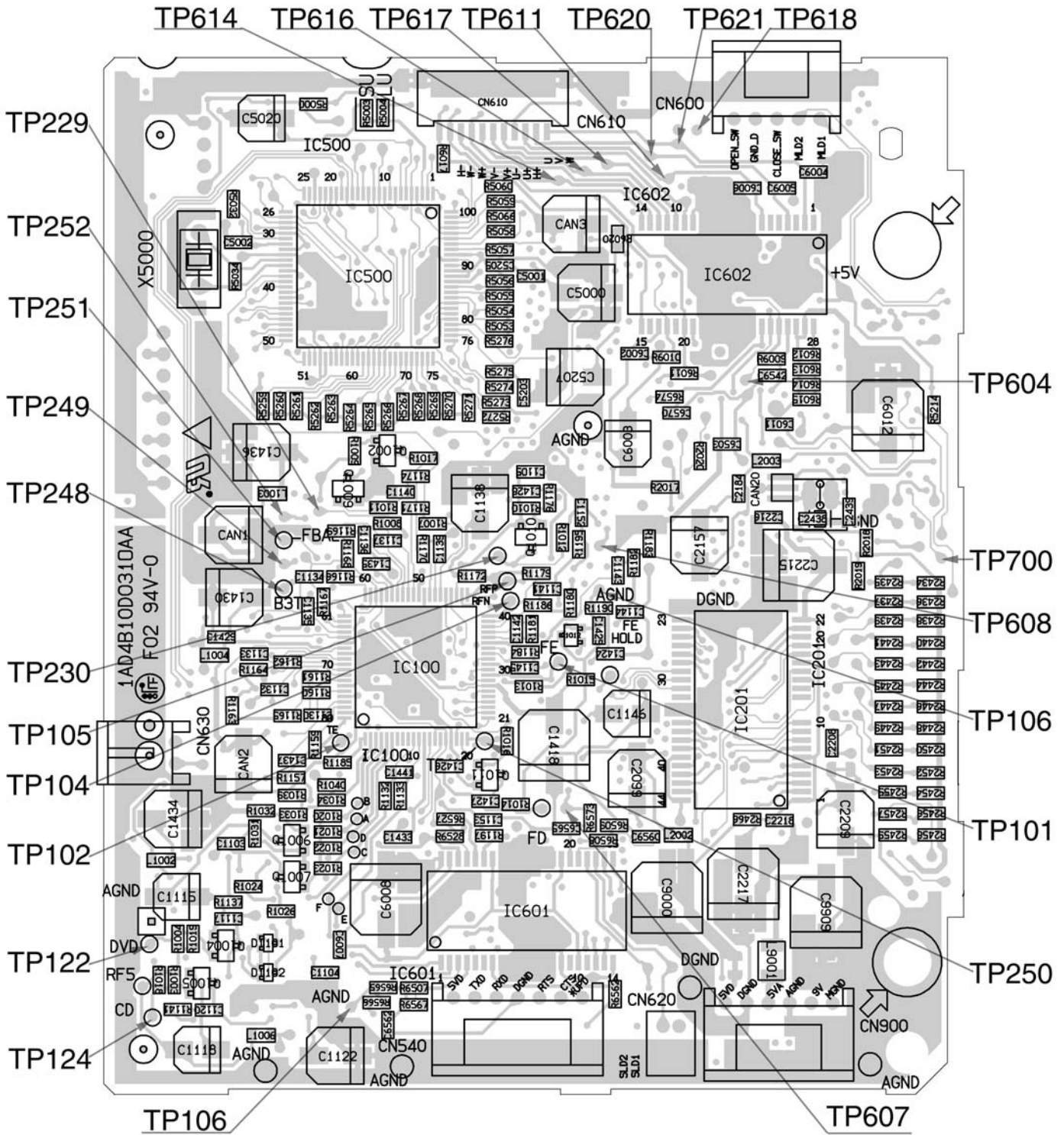

# DVD P.W.BOARD OPERATION(SIGNAL) (This is a basic signal.)

## 1. RF and Defection Signal

Each signal shown refers to WIRING ,SCHEMATIC DIAGRAM and Table of monitor signals.

### A. RF Signal during play mode.

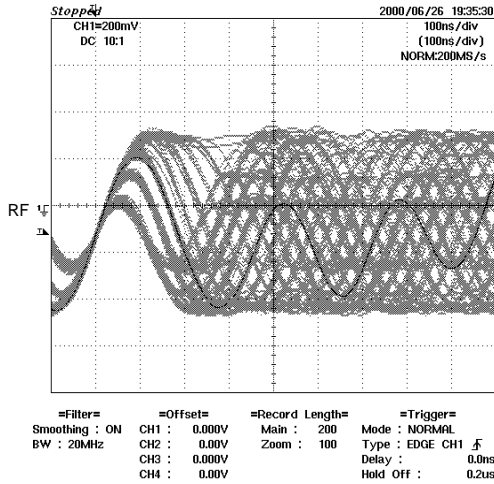

RF of DVD disc

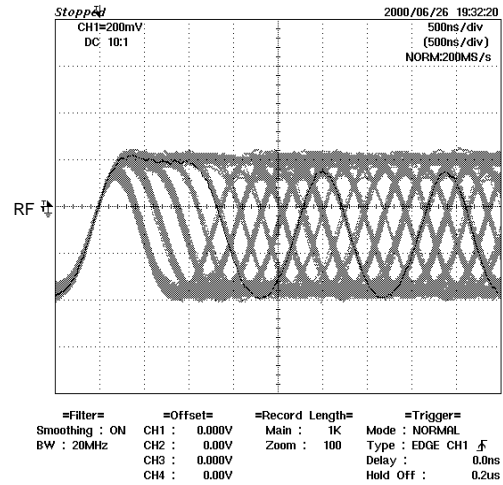

RF of CD disc

### B. Defection Signal (Detection of level down signal)

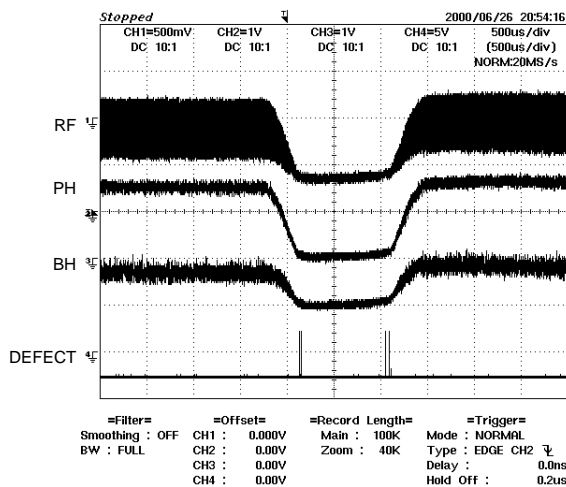

Scratched defect

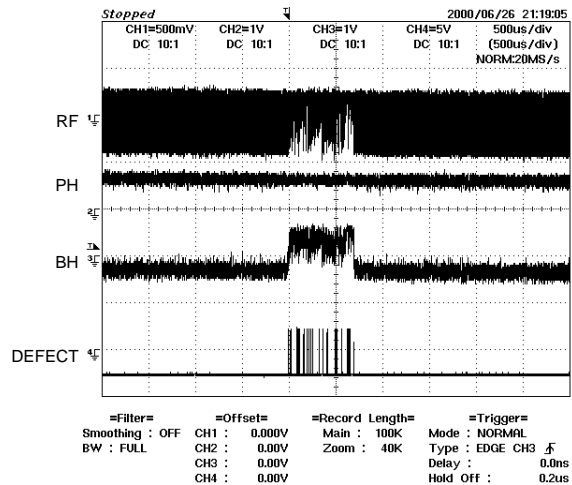

Interruption defect

## 2. Servo and Tray Control

### A. S-Curve signal by Focus search

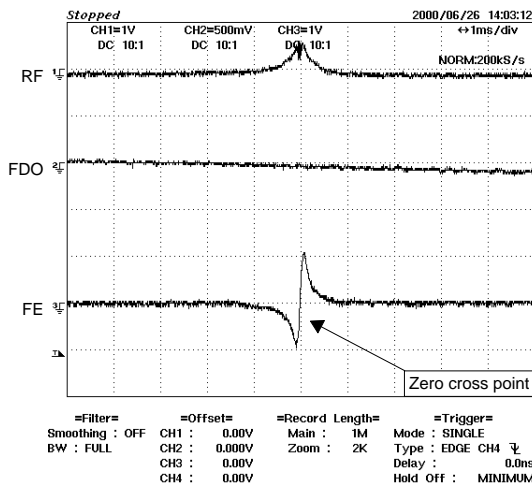

S-Curve of DVD Single Layered disc

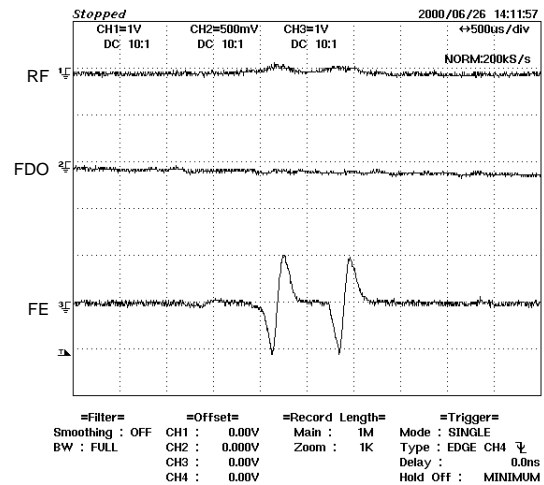

S-Curve of DVD Dual Layered disc



# DVD P.W.BOARD OPERATION(SIGNAL)

## B. Focus In and Focus Jump

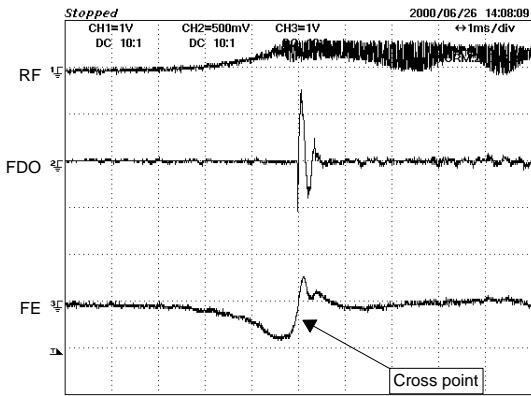

Stopped 2000/06/26 14:08:09  
 CH1=1V DC 10:1 CH2=500mV DC 10:1 CH3=1V  
 ←1ms/div  
 =Filter= =Offset= =Record Length= =Trigger=  
 Smoothing : OFF CH1 : 0.00V Main : 1M Mode : SINGLE  
 BW : FULL CH2 : 0.00V Zoom : 2K Type : EDGE CH4  
 CH3 : 0.00V Delay : 0.0ns  
 CH4 : 0.00V Hold Off : MINIMUM

Focus In

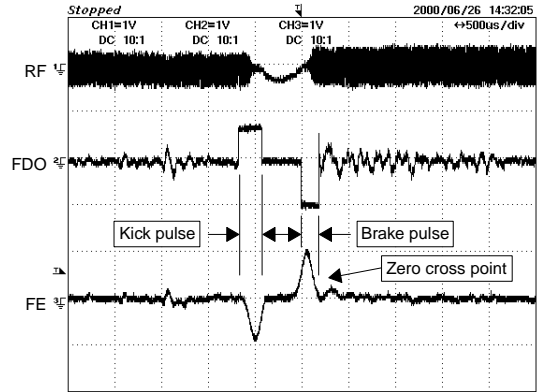

Stopped 2000/06/26 14:32:05  
 CH1=1V DC 10:1 CH2=1V DC 10:1 CH3=1V  
 ←500us/div  
 =Filter= =Offset= =Record Length= =Trigger=  
 Smoothing : OFF CH1 : 0.00V Main : 1M Mode : SINGLE  
 BW : FULL CH2 : 0.00V Zoom : 10K Type : EDGE CH3  
 CH3 : 0.00V Delay : 0.0ns  
 CH4 : 0.00V Hold Off : MINIMUM

Focus Jump

## C. Tracking Servo

### a. TE (Tracking Error) Signal.

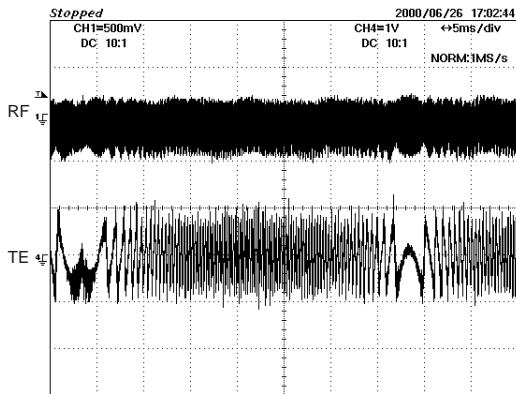

Stopped 2000/06/26 17:02:44  
 CH1=500mV DC 10:1 CH4=1V DC 10:1  
 ←5ms/div  
 NORM:1MS/s  
 =Filter= =Offset= =Record Length= =Trigger=  
 Smoothing : OFF CH1 : 0.000V Main : 1M Mode : SINGLE  
 BW : FULL CH2 : 0.000V Zoom : 50K Type : EDGE CH1  
 CH3 : 0.000V Delay : 1.700s  
 CH4 : 0.00V Hold Off : MINIMUM

TE Curve

### b. Track Jump Signal

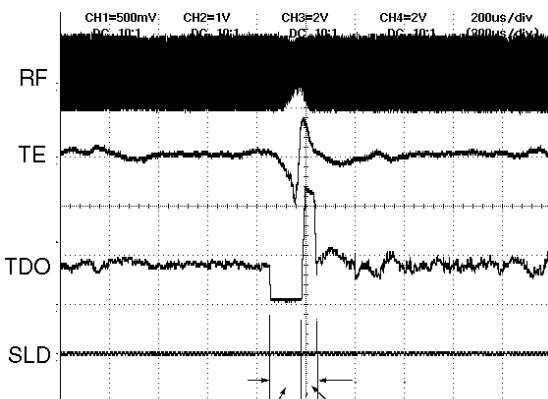

Kick Pulse Brake Pulse

One Track Jump

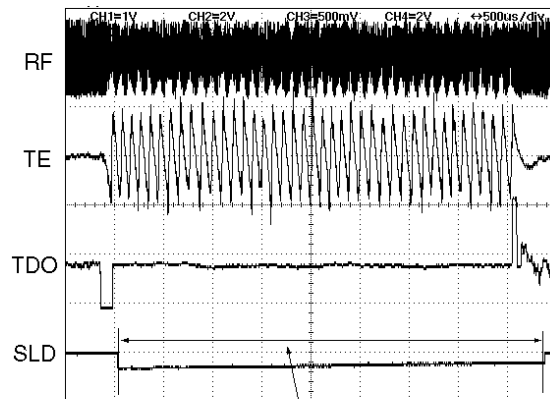

Sled Drive

42 Track Jump Out -> In

# DVD P.W.BOARD OPERATION(SIGNAL)

## D. Sled Servo (Sled motor drive signal)

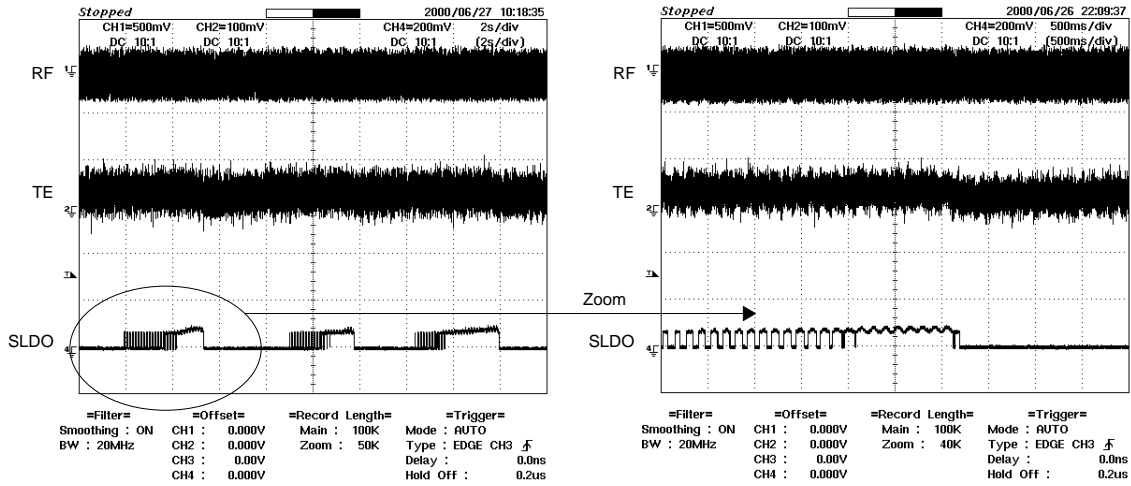

## E. Spindle Servo (Spindle motor drive signal)

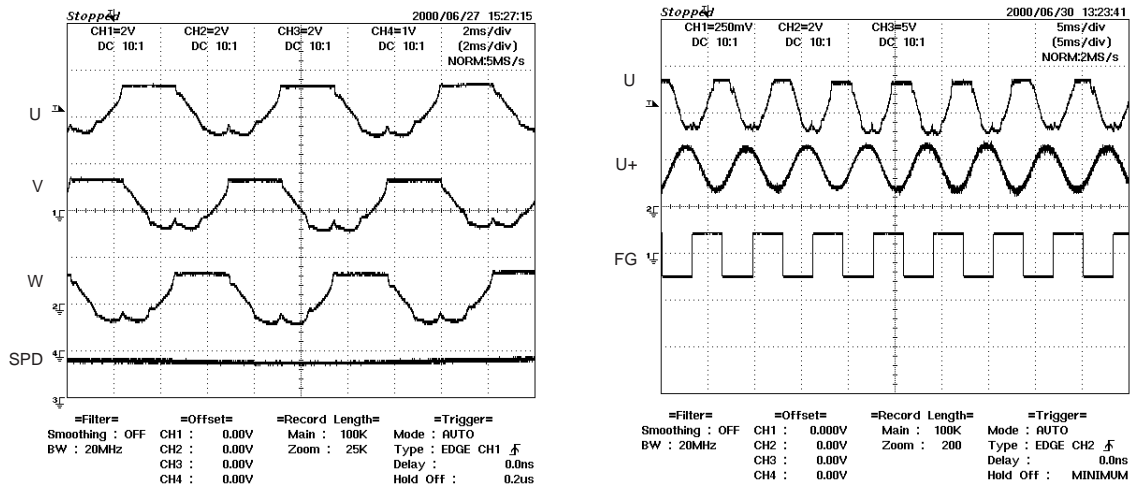

Spindle Drive (U, V, W)

Spindle (W, W+, FG)

## F. Tray open and close

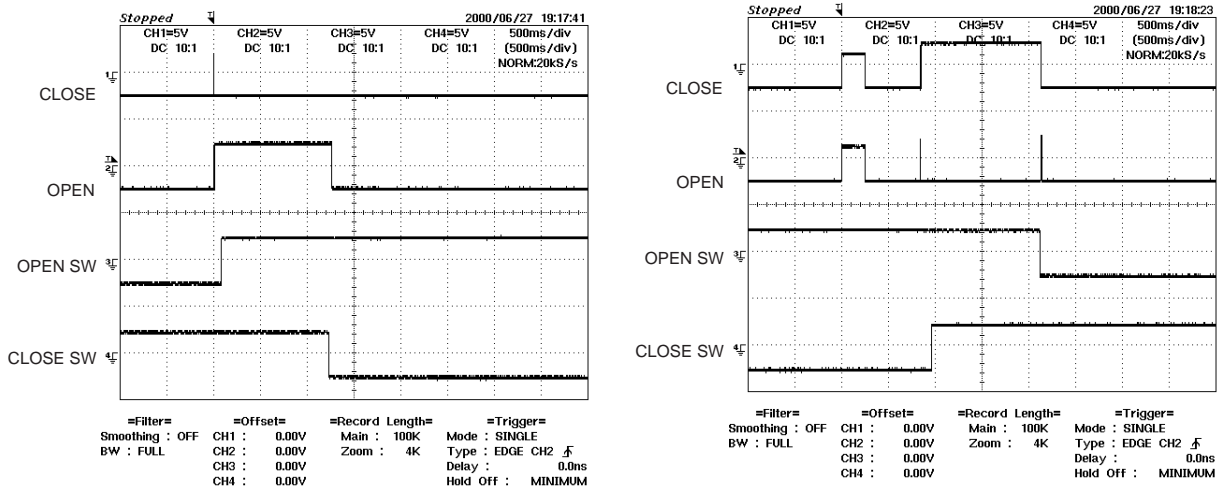

Tray Close

Tray Open

# DVD P.W.BOARD OPERATION(SIGNAL)

## 3. Decoder

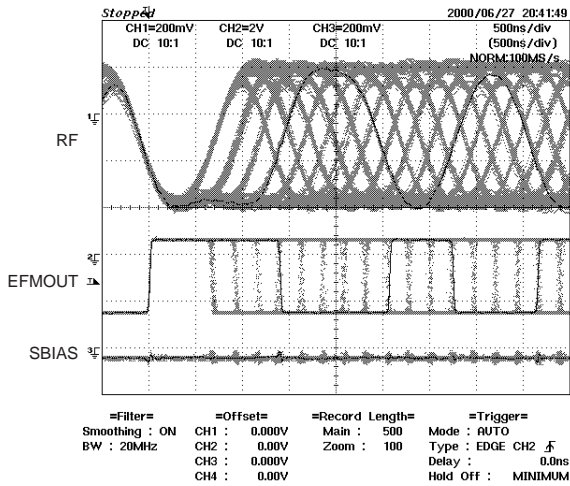

RF, EFMOUT, SBAIS

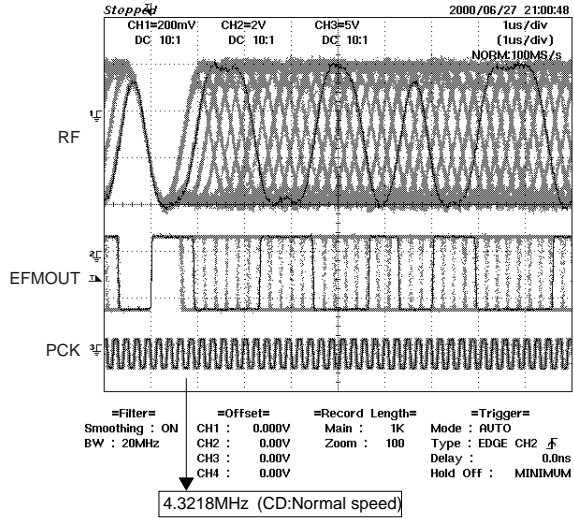

RF, EFMOUT, PCK

## 4. Reset Timing for Microm Controller

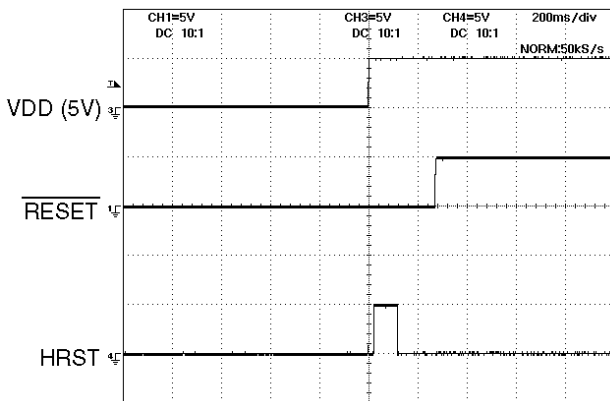

Reset Timing

## 5. Anti-Defect Processing

### A. Disturbance by Defect

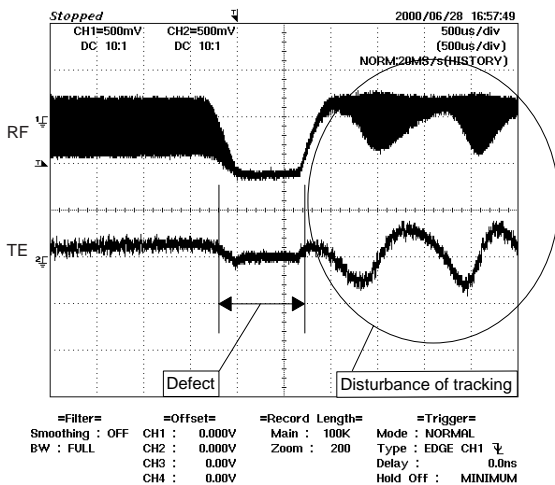

TE disturbance at Defect

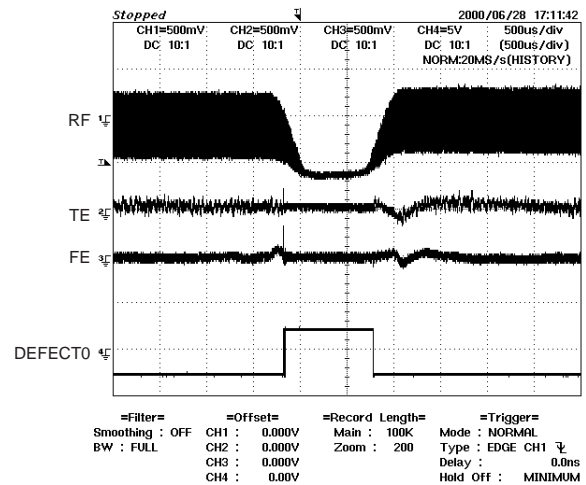

Suppressed disturbance by TE,FE hold process

# DVD P.W.BOARD OPERATION(SIGNAL)

## B. Circuit block of Anti-Defect

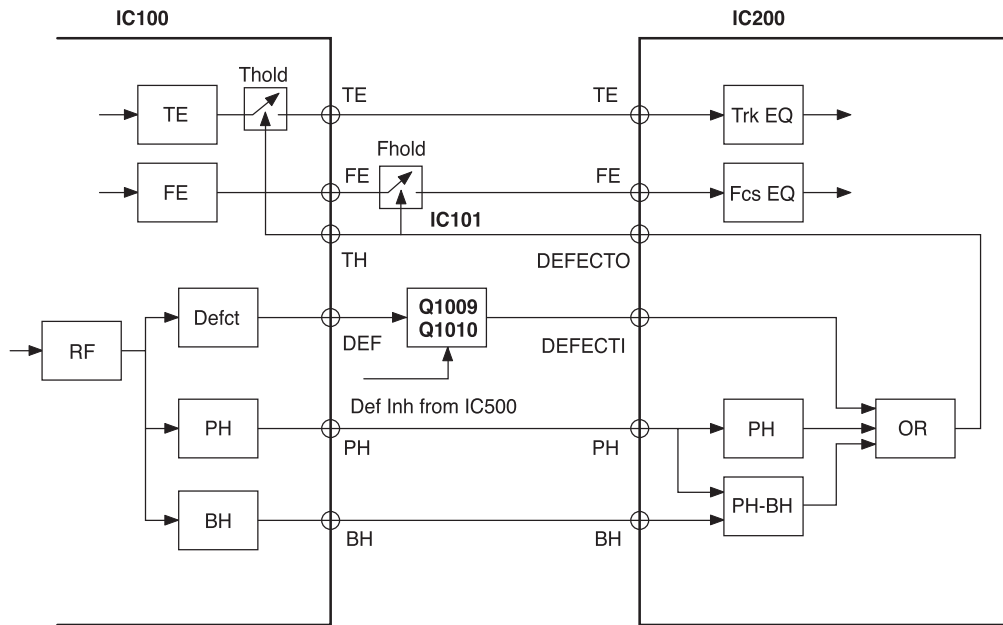

### 6. Start-up program

#### A. Disc type Identification

##### a. In the case of DVD Dual Disc

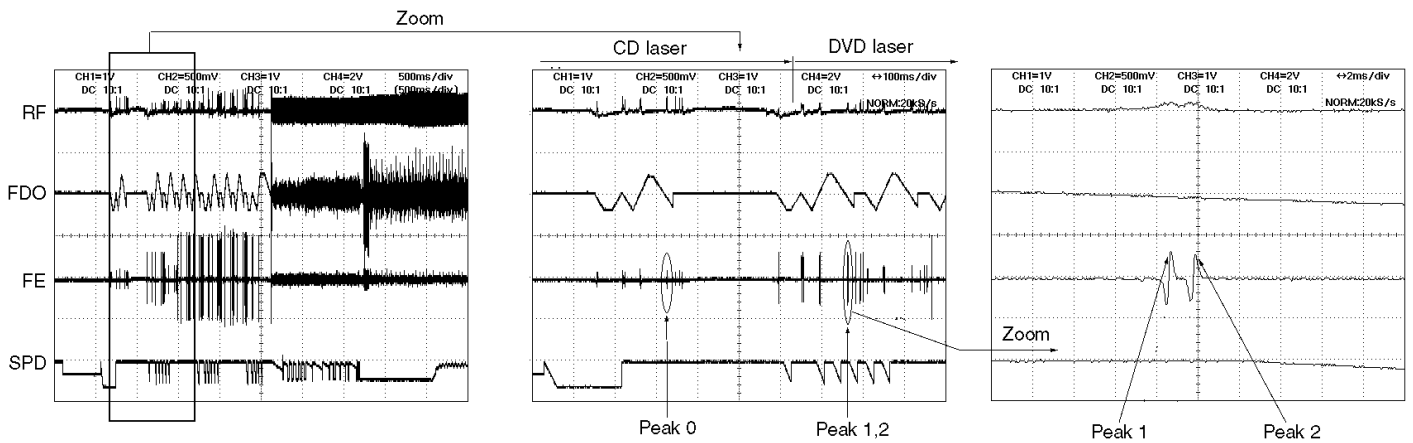

##### b. In the case of DVD Single Disc

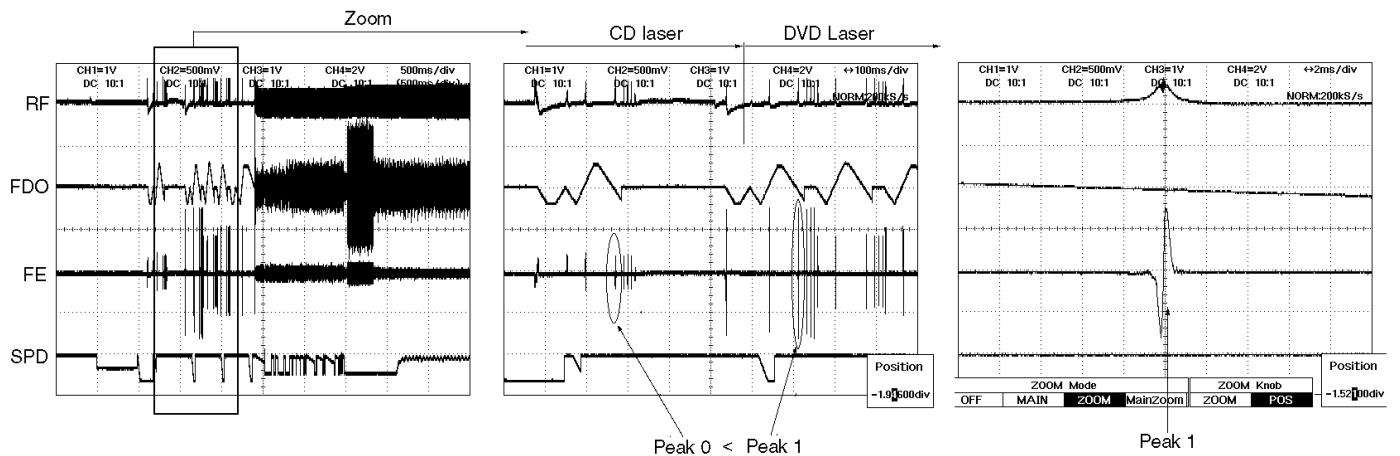

# DVD P.W.BOARD OPERATION(SIGNAL)

## c. In the case of CD Disc

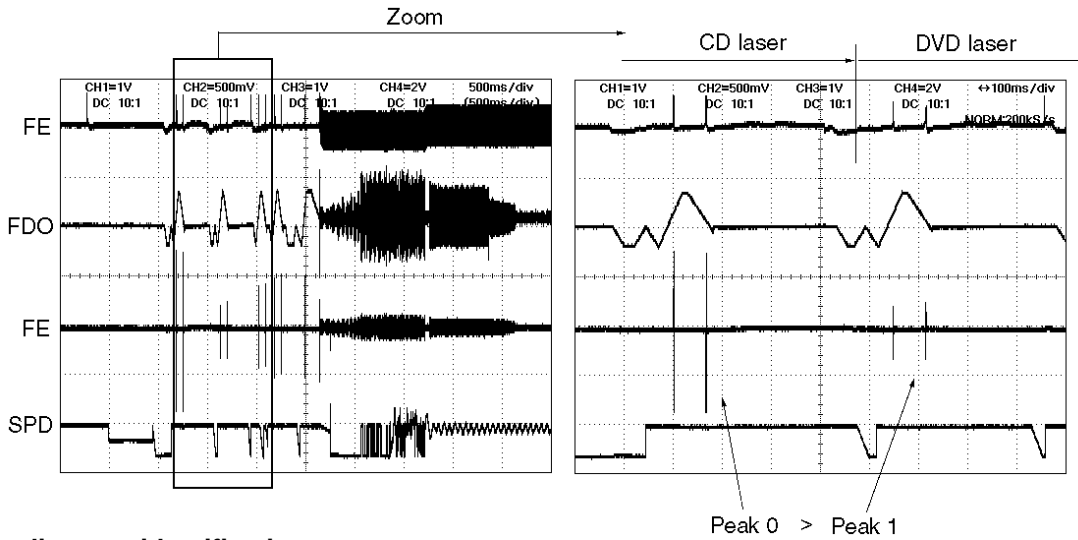

## B. Disc diameter identification

### a. In the case of 12cm Disc

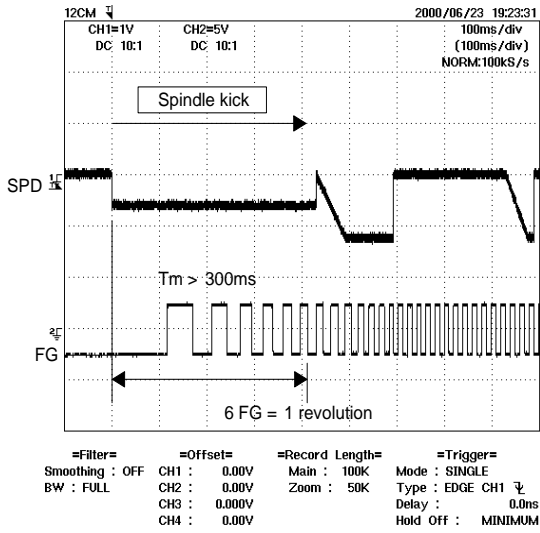

### b. In the case of 8cm Disc

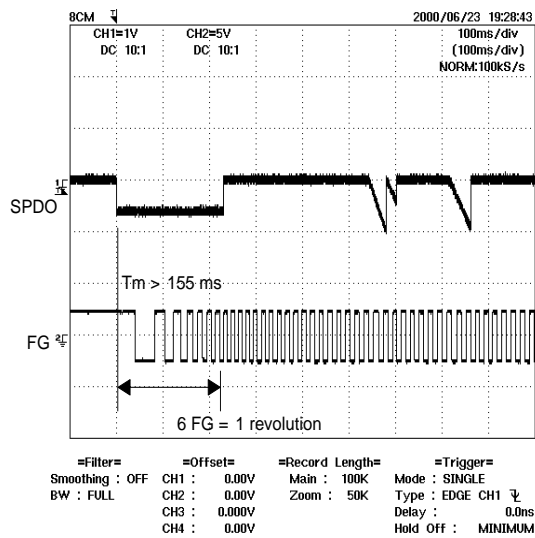

### c. In the case of NO Disc

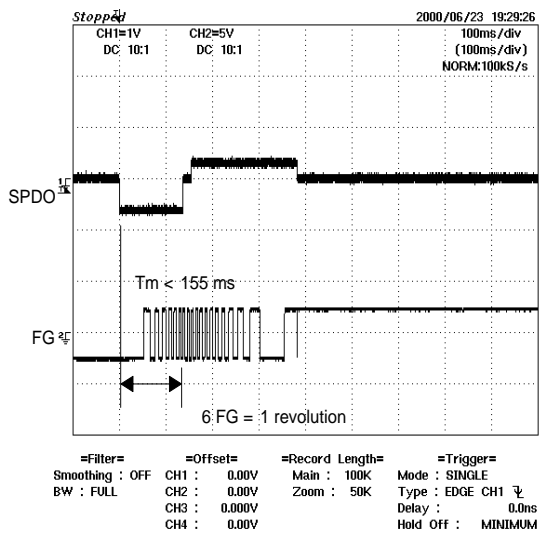

# DVD P.W.BOARD OPERATION(SIGNAL)

## 7. Adjustment (Auto Adjustment)

### A. SGC(Signal Gain Control) Adjustment

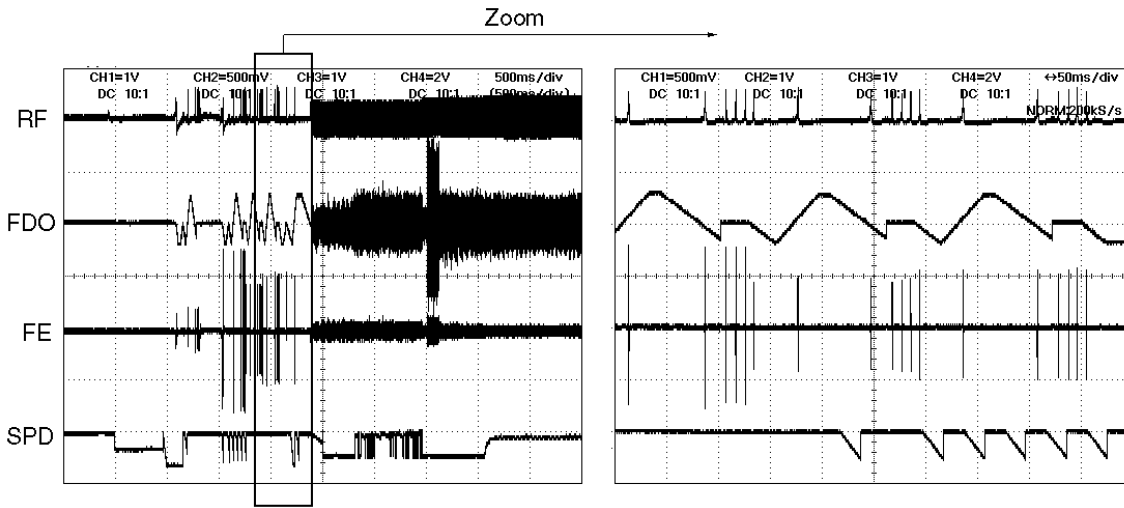

### B. Tracking Balance Adjustment

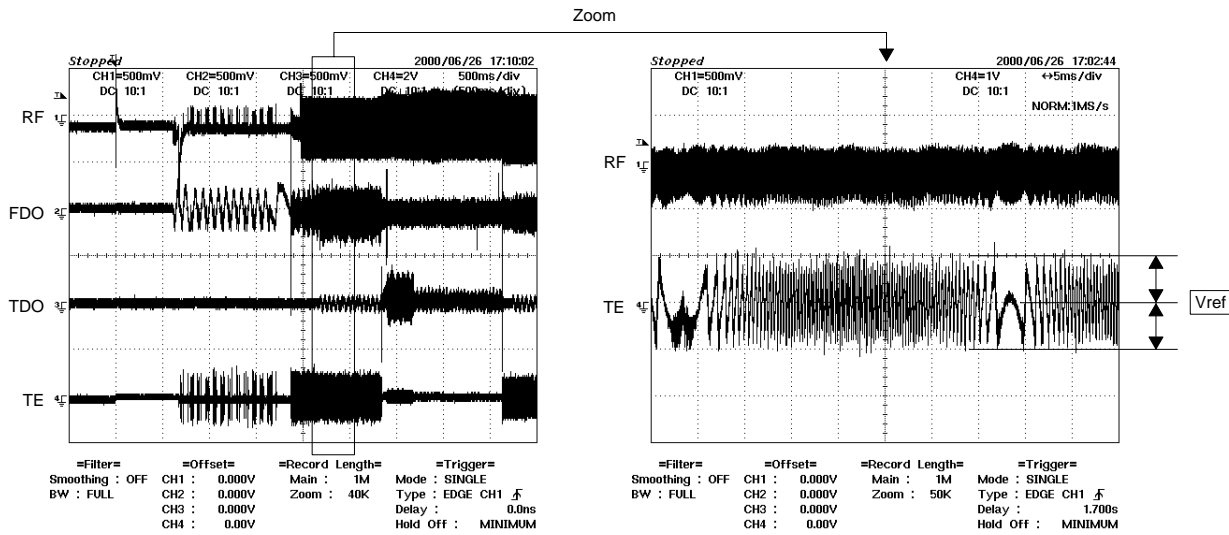

# DVD P.W.BOARD OPERATION(SIGNAL)

## C. Focus and Tracking Gain Adjustment

### a. Focus gain Adjustment

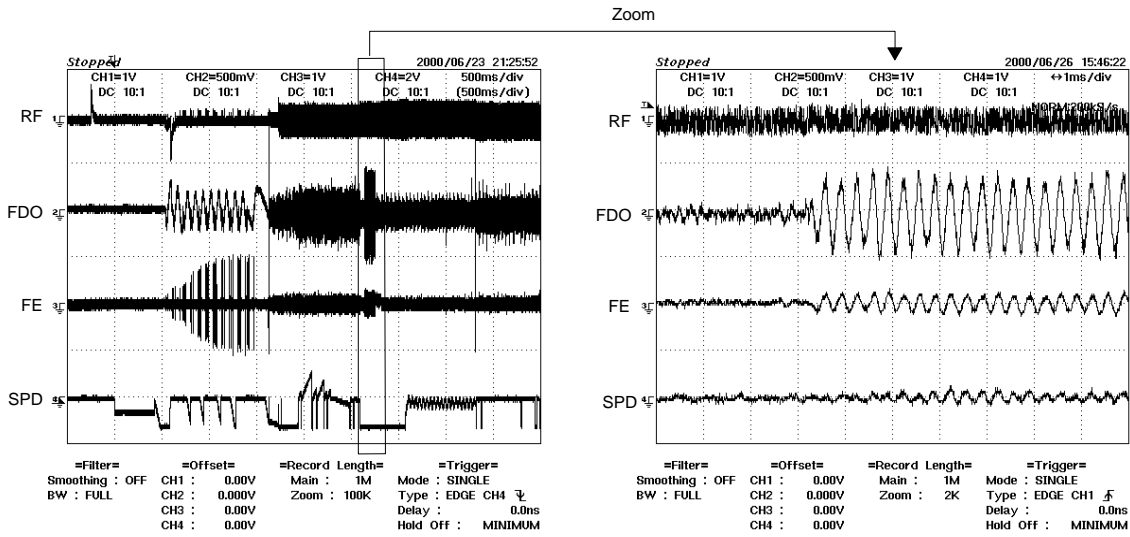

### b. Tracking Gain Adjustment

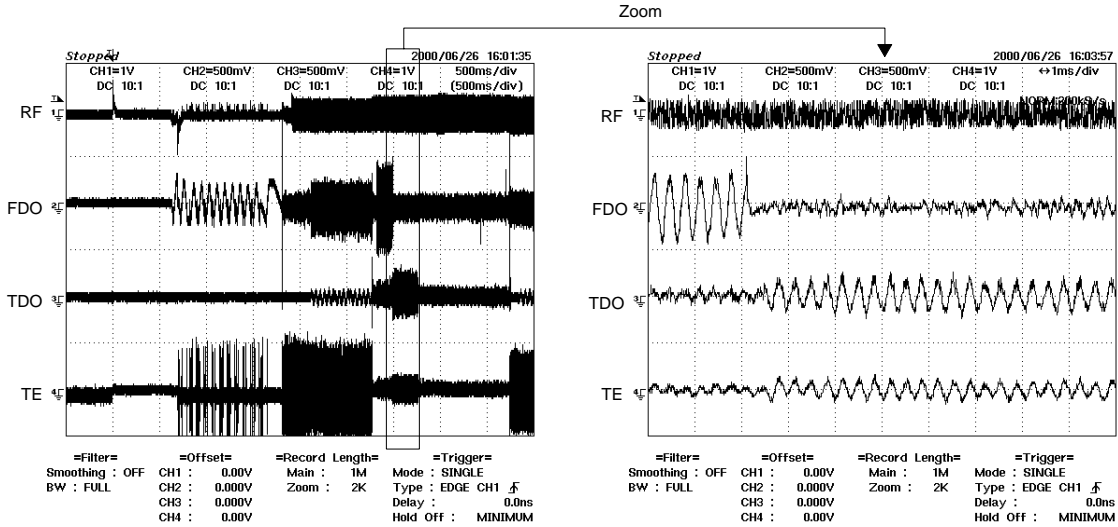

# DVD START-UP PROGRAM FLOW CHART

(This is a basic start-up program flow chart.)

## 1. Disc Identification

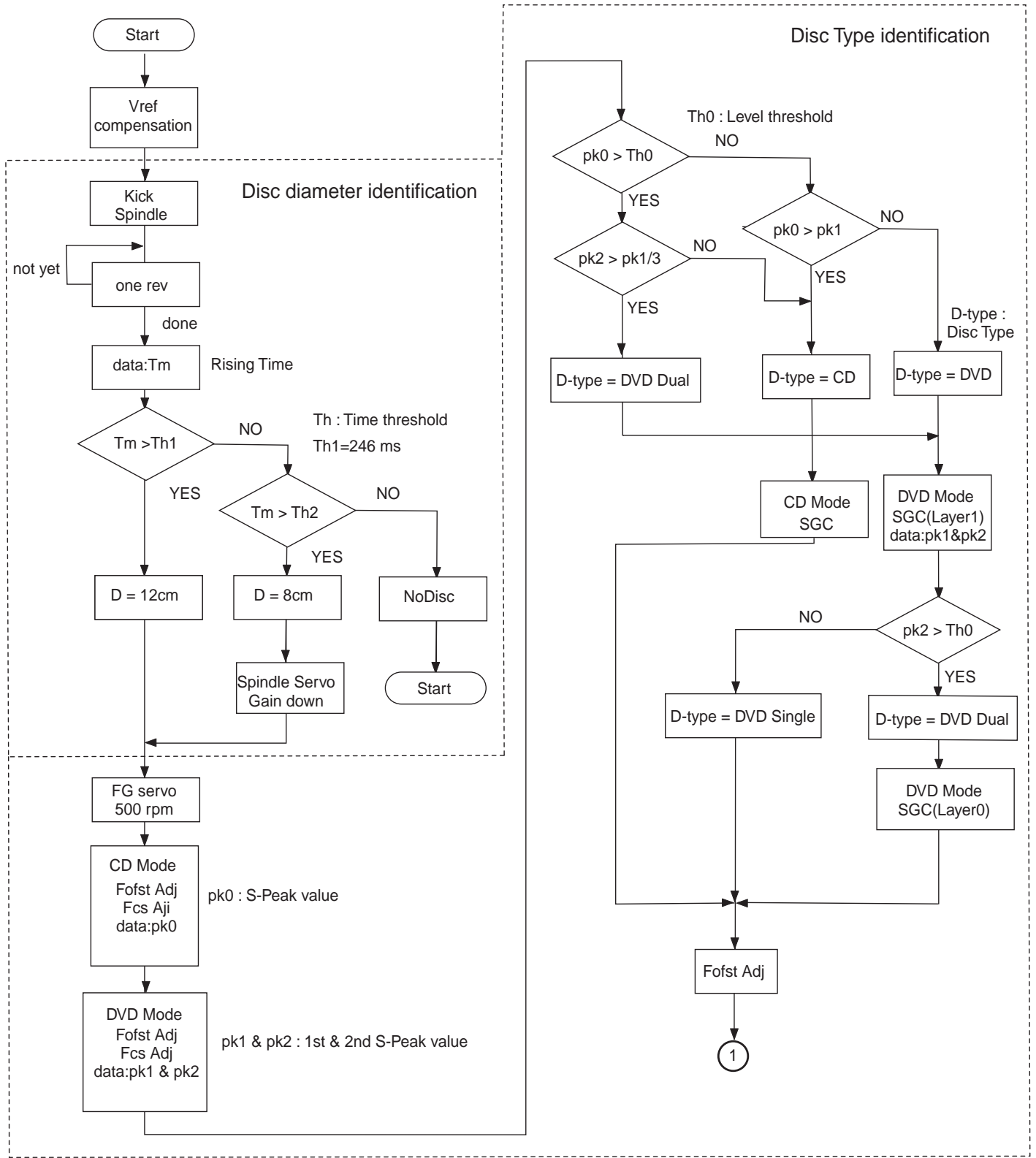



# DVD START-UP PROGRAM FLOW CHART

## 2. Fundamental and additional auto adjustment

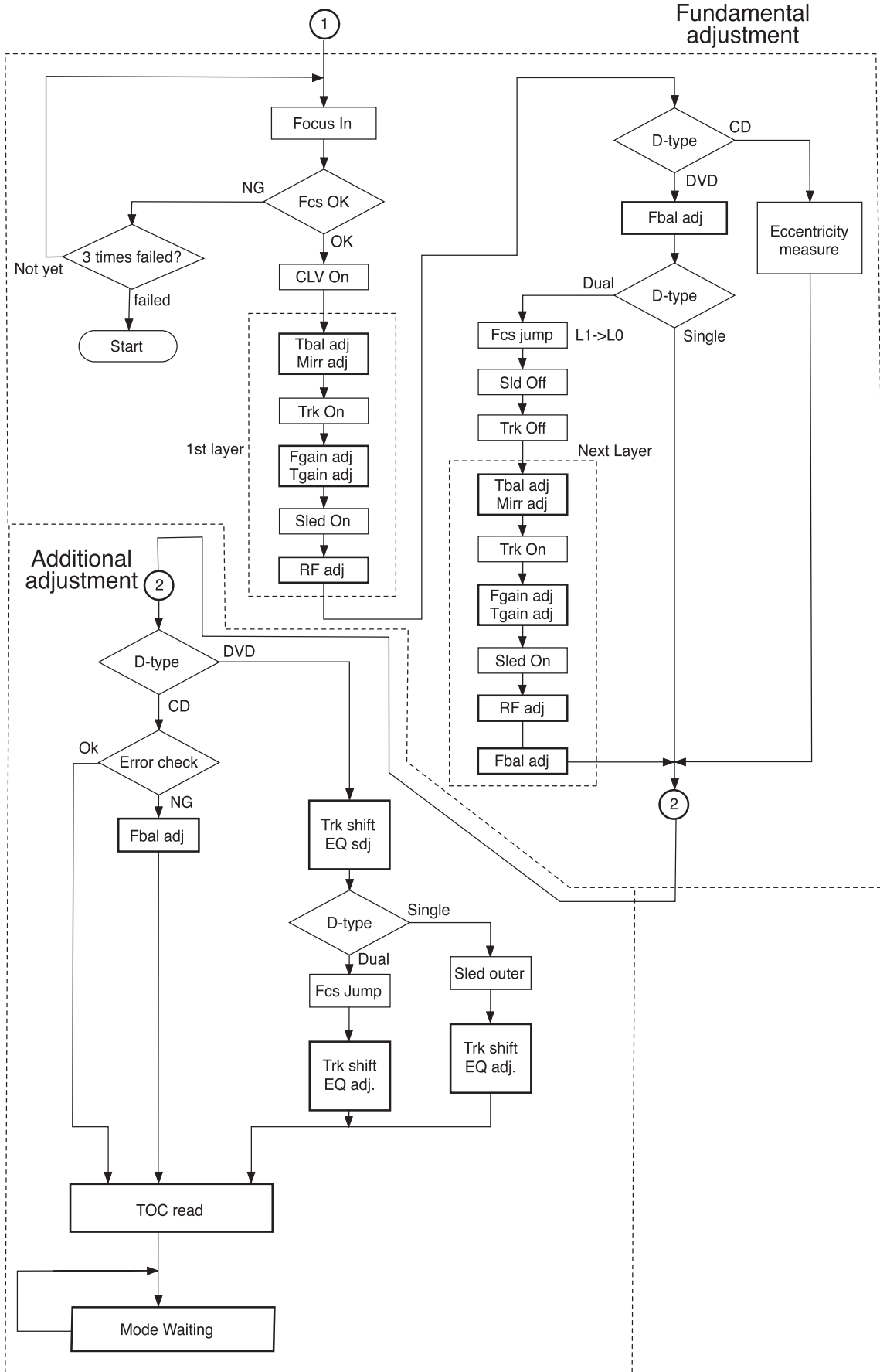

# MPEG AND FRONT END P.W.BOARD OPERATION(BLOCK DIAGRAM)

(This is a basic block diagram.)

